

This guide is intended for you, the ROAD HAULAGE PROFESSIONAL.

It outlines the essential recommendations for use and maintenance of the system to ensure operation in optimum conditions of safety.

This guide describes normal conditions of use. If you want additional explanations concerning the contents of the guide or any particular conditions of use of this vehicle, please get in touch with us.

Please keep this booklet in a safe place.



High Productivity transport solutions.....

tel: 03 21 79 43 00

fax: 03 21 79 43 01

web address: www.benalu.com

postal address: BENALU SAS - Rue Fresnel - 62800 LIEVIN - FRANCE

All illustrations and photos are non-contractual and simply offer examples.

TABLE OF CONTENTS

Coupling	3
Uncoupling	5
Essential safety and operating instructions	6
Opening the rear door	14
Dumping instructions	26
Operating instructions	29
Particularities of straight trucks	37
Particularities of cereal dumpers	38
Pallet-carrier vehicles	41
Tipping container carrier	42
Servicing	47
Notes	53

MAX : 170 BAR

D036967 - 00

Fig. 3-1

Couple the semi-trailer to the tractor unit or the trailer to the straight-truck according to the instructions given in the general instruction manual.

Unless otherwise specified on the hydraulic pressure indicator plate (fig. 3-1), the equipment in our dump bodies is designed to operate at a maximum working pressure of 170 bar.

Optional equipment

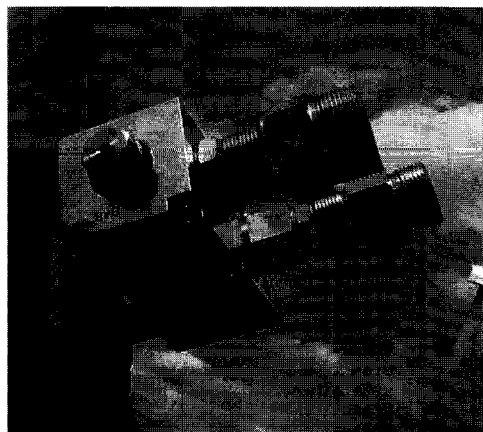

Fig. 3-2

Certain hydraulic devices deliver a higher pressure, in which case a sealed pressure limiter (fig. 3-2) should be fitted to the circuit so that it delivers a maximum of 170 bar to the hoist.

COUPLING

Connect the hoist hydraulic circuit, ensuring:

- that the tractor unit hoses are in perfect condition,
- that the coupling is free of all foreign bodies which could damage the hydraulic system,
- that the supply hose coupling is completely tightened and blocked,
- that the oil level in the tank is sufficient to enable the hoist to be raised,
- that the oil contains neither water nor impurities which could damage the seals or scratch the hoist tubes.

If a pressure limiter is mounted on the hoist, connect:

- the "supply" hose (fig. 4-1),
- then the "boost oil return" hose (fig. 4-2).

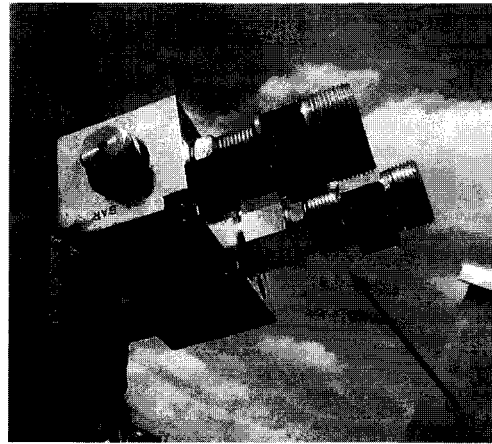

Fig. 4-1

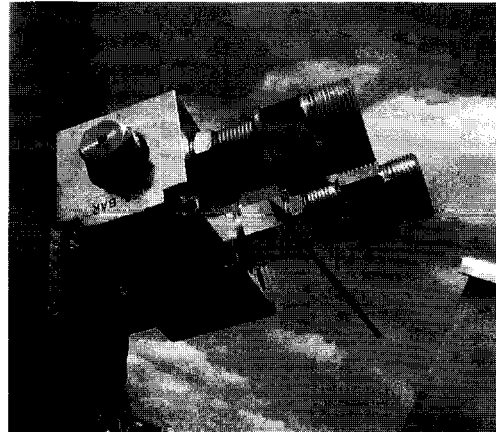

Fig. 4-2

A semi-trailer or a dumper trailer is uncoupled in accordance with the instructions given in the general instruction manual.

The hydraulic circuit may only be uncoupled:

- with dump body resting on the chassis,
- with pump disengaged so that the hydraulic circuit is not pressurised..



In the uncoupled vehicle position, raising with load is strictly prohibited.

ESSENTIAL SAFETY AND OPERATING INSTRUCTIONS

GENERAL

Dumping operations are the responsibility of the operator who, as an experienced professional, must abide by the essential safety rules recalled below:



YOU MUST NEVER STAND UNDER A RAISED DUMP BODY, WHETHER EMPTY OR LADEN, OR IN ITS IMMEDIATE VICINITY.

Prior to any unladen maintenance work, it is **ESSENTIAL** to install a safety support leg.

- ⇒ Avoid carrying out dumping operations in stormy, windy conditions as this could compromise the stability of the articulated assembly.
- ⇒ All the articulation and running gear elements must be in good working order.
- ⇒ The tyres must be inflated to the operating pressure recommended by the manufacturer.
- ⇒ **Never leave the dumping area before the dump body has been completely lowered.**

An extract from the instructions in this manual is recalled on the plate or self-adhesive label stuck on the front of the dump body (page 7).

REMINDER OF ESSENTIAL DUMPING INSTRUCTIONS

1. THE LOAD MUST BE EVENLY DISTRIBUTED

2. BEFORE DUMPING

The tractor unit and its front wheels must be aligned with the semi-trailer and on flat, horizontal, stable, hard ground.
When the vehicle is equipped with rear stability legs, they MUST be used.

3. DURING DUMPING

Ensure that nobody is in the immediate vicinity of the vehicle.
The operator must remain at the controls to supervise smooth running of the operation.
Jolting the ram or making any movements with the vehicle is prohibited.
If the product does not flow out, immediately stop dumping and slowly and SMOOTHLY lower the dump body or tanker.

4. AFTER DUMPING

Do not leave the dumping zone until the dump body or tanker has been completely lowered.

ESSENTIAL SAFETY AND OPERATING INSTRUCTIONS

Audible movement warning device

When the dump body is raised, this triggers an audible warning device.

Pressurising the hoist allows contact by a pressure switch which supplies the warning device, which will only stop when the body is lowered onto the chassis.

Ensure that hydraulic circuit decompression is sufficient to prevent inadvertent start-up of the system (pressure switch calibrated to 3 bar). To do this, keep the control in the down position for a few seconds after the dump body has come to rest on the chassis.

The pressure switch must be electrically supplied by a 24V current delivered to pin 4 of the 24S connector.



Fig. 8-1

LOADING

The variety of materials transported means that they can be influenced by various climatic conditions (frost, partial wetting of the product).

These circumstances can cause balance problems at dumping (product clumping) which could cause overtipping.

It is essential to consult the loader for a definition of the product to be placed between the dump body and the load to facilitate flowing for risk-free dumping.

It may also be necessary to place a product between the bottom and the load owing to the corrosive or other nature of the product transported.

The load must always be evenly distributed longitudinally (fig. 10-1) and transversely (fig. 10-2) within the authorised payload limits, rather than concentrated at the front or back (fig. 10-3) or on the same side (fig. 10-4).

If the load is not homogeneous, then the heaviest items should be at the bottom of the dump body rather than at the top.

Loads resting against the doors should not be too great.

The load must not protrude above the sidewalls.

Complying with these basic instructions will improve running and unloading conditions.

ESSENTIAL SAFETY AND OPERATING INSTRUCTIONS

ENGLISH

Fig. 10-1

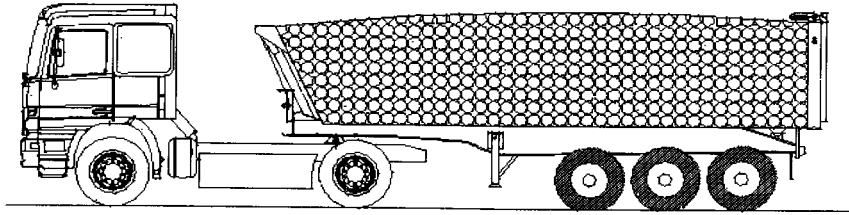

YES

Fig. 10-2

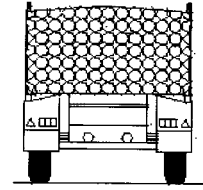

YES

Fig. 10-3

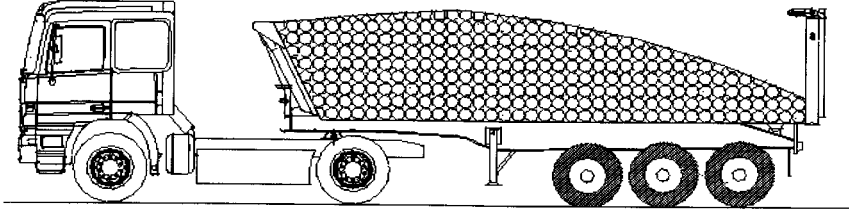

NO

Fig. 10-4

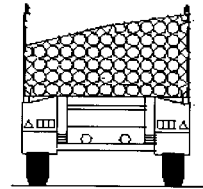

NO

DANGER

DANGER

LOADING (cont.)

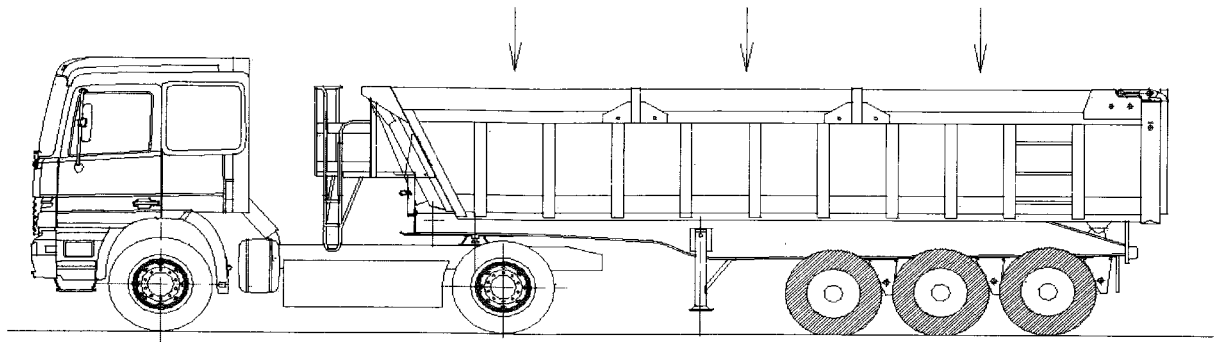

Fig. 11-1

Certain dump bodies are pre-equipped with height extender mountings for increasing the initial payload volume, within the payload limits, according to the density of the materials to be transported (fig. 11-1).

Transporting certain products requires installation of a protective net or tarpaulin; In this case, before departure, check that they are correctly tied down by elastic straps, hasps, bars or spacer chains, or bracing bows, which must be in good condition.

In any case, installing a tarpaulin will bring down tractor unit fuel consumption.

INSTRUCTIONS PRIOR TO DUMPING

Dumping **MUST** be carried out:

1. With semi-trailer coupled and not uncoupled as shown in Fig. 12-1.
2. On flat, horizontal, stable and hard ground, unlike in Fig. 12-2.
3. All tyres must be fully bearing on the ground, unlike in Fig. 12-3.

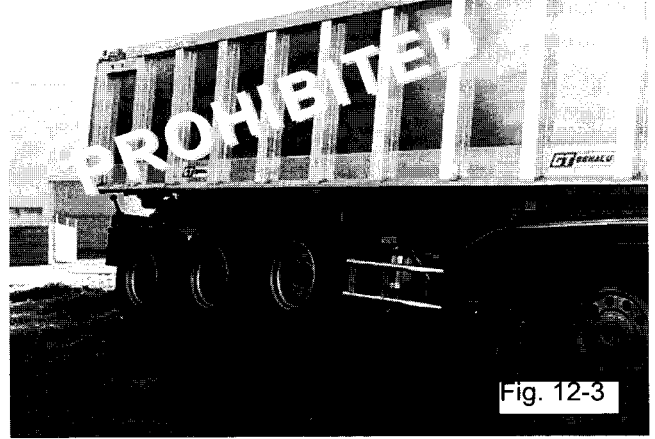
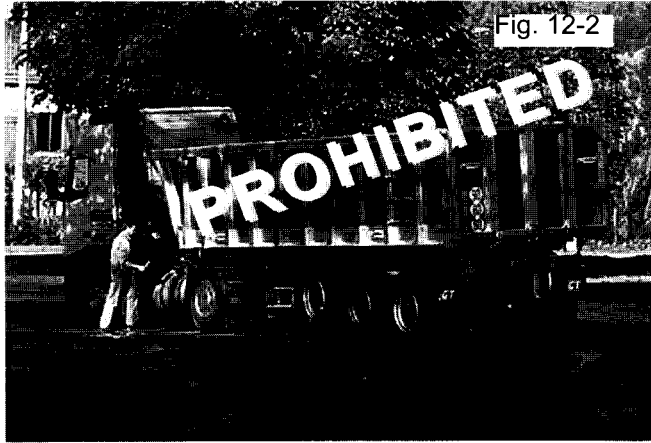
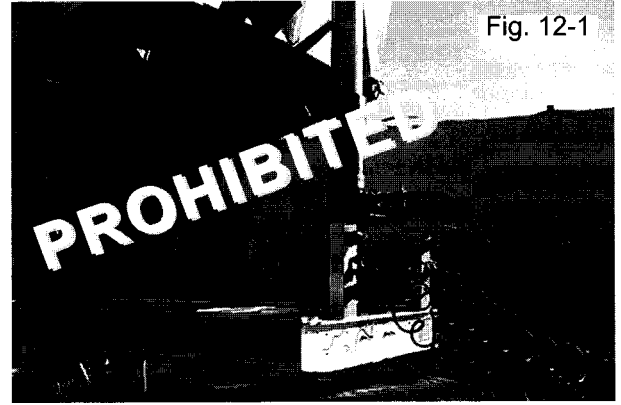

Fig. 13-1

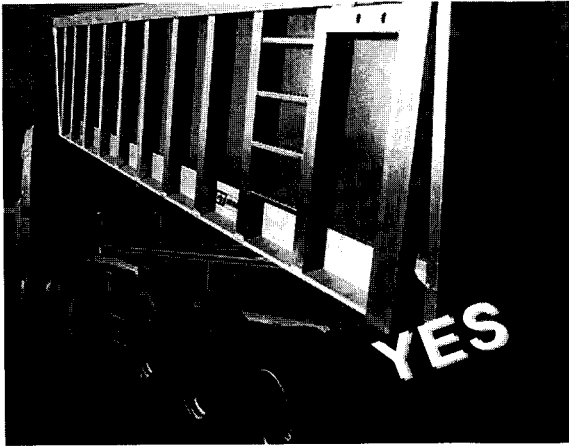

Fig. 13-2



INSTRUCTIONS PRIOR TO DUMPING (cont.)

4. The tractor unit and steering wheels must be aligned with the longitudinal axis of the semi-trailer (fig. 13-1). No dumping is allowed if the tractor unit is not in line (fig. 13-2).
5. No infrastructure should impede dumping (to be checked).
6. All work done below overhead electrical wires constitutes a lethal hazard and requires authorisation and supervision by the Official Organisation.
7. All work done below overhead railway power lines also constitutes a lethal hazard and is subject to authorisation by the railway authority.
8. The articulated assembly must be braked.
9. The hydraulic coupling brackets must be fully screwed-in.
10. When the vehicle is equipped with them, the use of rear stability legs is **MANDATORY**.

OPENING THE REAR DOOR

Warning: When unlocking the doors and before opening them, take care to keep clear of any falling materials. Beware of sudden opening of the operating devices, particularly the lock bars (fig. 14-1), or of the doors under the pressure of the materials behind them.

Manual opening of the rear double-doors

unlock the doors and open them (fig. 14-2)
- fold back the doors and secure them against the sidewall of the dumper body before starting dumping (fig. 14-3 & 14-4).

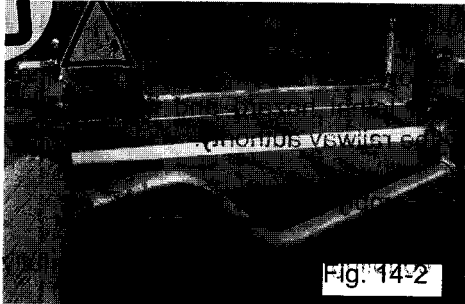

When closing the door, make sure that the mechanism is properly locked. Do not forget to install the safety pin (Fig. 14-5) or any other security device (blocking pin, etc.).

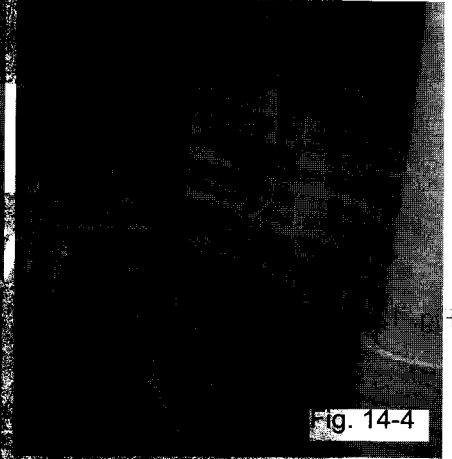

SAMPLING HATCH

When the rear door is equipped with one or two sampling hatches, they must be open to partly remove some of the materials pressing against the doors before they are opened (fluid flow products).

Take all safety measures to keep clear of falling product (Fig. 15-1).

To complete unloading via the rear hatches, they must be opened symmetrically to allow satisfactory product flow (fig. 15-2).

Total unloading through a single hatch **IS PROHIBITED** owing to the risk of overtipping.



Fig. 15-1



Fig. 15-2

OPENING THE REAR DOOR

Universal door swing function

The door frame is unlocked by hooks which are mechanically or pneumatically actuated by raising the dump body (fig. 16-1).

Opening occurs when the hoist reaches 1.5 Expansion MAX. (Fig. 16-2 & 16-3).

ENGLISH

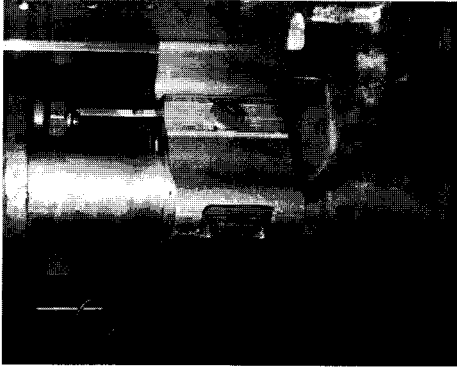

Fig. 16-1

If the rear frame fails to open:

- stop dumping immediately and smoothly,
- lower the dump body,
- adjust the opening of the rear hooks.

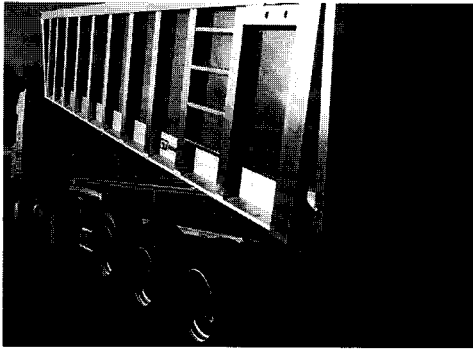

Fig. 16-2



Fig. 16-3

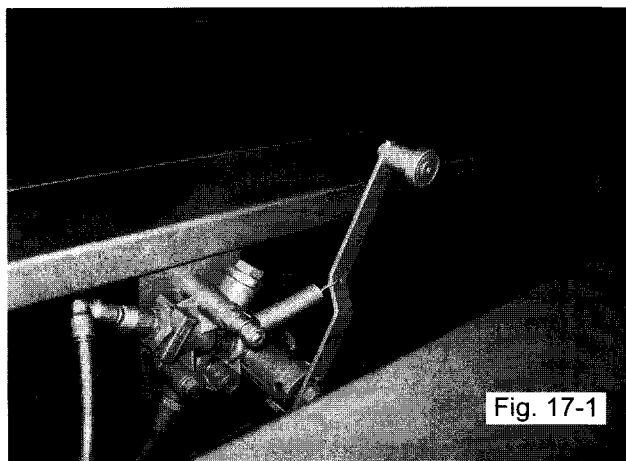

Fig. 17-1

Pneumatic hook opening swing function

Unlocking one of the doors is by means of hooks actuated pneumatically by raising the dump body.

A distributor controlled by a lever which comes into contact with the bottom of the body supplies a pneumatic hoist when dumping starts (fig. 17-1).

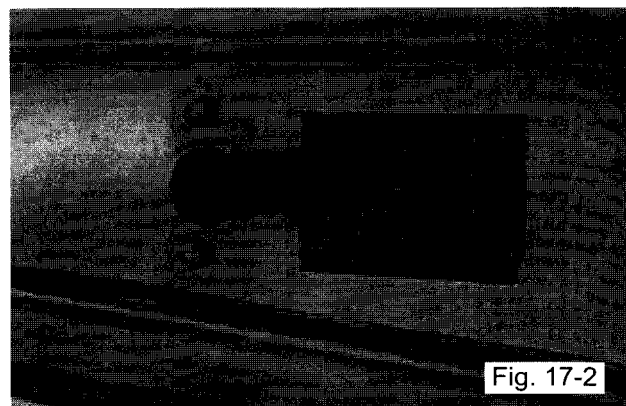

Fig. 17-2

An isolating valve is used to neutralise opening of the hooks, for example when the sample hatch is being used.

A sticker describes operation of the valve (Fig. 17-2).